



Car Refinishing

Premium Performance Spray Guns For High Quality Finishing



PROVEN QUALITY. LEADING TECHNOLOGY.



WHY PARTNER WITH GRACO?

GRACO@HOME ON ALL SURFACES

- **85 Years of Experience in Car Refinishing**
- **Dedicated Gun Manufacturing Facility**
- **Multilingual Customer Service and Technical Assistance Teams**
- **Delivery in 24 - 48 Hours, Inside the EU FOB**
- **Parts Availability of About 97%**
- **Continuous Investment Into New Product Development**
- **Complete Product line With Premium Class RAZOR™ Guns and High Value LT-Series**

RAZOR

HVLP Spray Guns

Features and Benefits

- Provides generous material flow that helps get the job done quickly
- Offers exceptional atomization rate
- Promotes a superior finish
- Proven effective for clear coat, base coat or primer

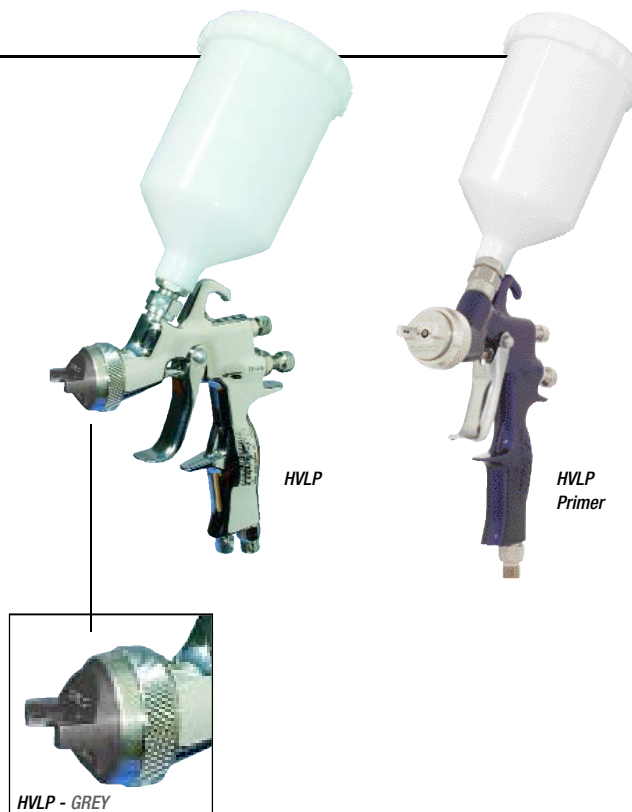

Ordering Information

Gun Part No.	Air Cap	Nozzle	Needle Tip & Assembly	Air Consumption	Air Inlet Size	Recommended Usage	Instruction Manual
HVLP							
288566 1.0 mm	253824	253792	288751 – tip 253769 – assy	407 lpm @ 2 bar (29 psi)	1/4" npsm(m)	Clear and base coats	312101
288567 1.2 mm	253824	253793	288751 – tip 253769 – assy	407 lpm @ 2 bar (29 psi)	1/4" npsm(m)	Clear and base coats	312101
288568 1.3 mm	253824	253794	288752 – tip 253771 – assy	407 lpm @ 2 bar (29 psi)	1/4" npsm(m)	Clear and base coats	312101
288569 1.4 mm	253824	253795	253917 – tip 253772 – assy	407 lpm @ 2 bar (29 psi)	1/4" npsm(m)	Clear and base coats	312101
288570 1.5 mm	253824	253796	253917 – tip 253772 – assy	407 lpm @ 2 bar (29 psi)	1/4" npsm(m)	Clear and base coats	312101
288571 1.7 mm	253824	253797	253917 – tip 253772 – assy	407 lpm @ 2 bar (29 psi)	1/4" npsm(m)	Clear and base coats	312101

Gun Part No.	Air Cap	Nozzle	Needle Tip & Assembly	Air Consumption	Air Inlet Size	Recommended Usage	Instruction Manual
HVLP Primer							
288572 1.5 mm	253828	253789	253917 – tip 253772 – assy	407 lpm @ 2 bar (29 psi)	1/4" npsm(m)	Primer	312101
288573 1.8 mm	253828	253790	234779 – tip 253774 – assy	407 lpm @ 2 bar (29 psi)	1/4" npsm(m)	Primer	312101
288574 2.3 mm	253829	253791	234779 – tip 253774 – assy	407 lpm @ 2 bar (29 psi)	1/4" npsm(m)	Primer	312101

RAZOR

LVLP Spray Guns

Features and Benefits

- For shops where air supply is limited
- Low volume, low pressure guns optimized for clear coat
- Offers amazing transfer efficiency
- Lightweight, ergonomic gun body for painter comfort
- Provides wide spray patterns and remarkable material flow

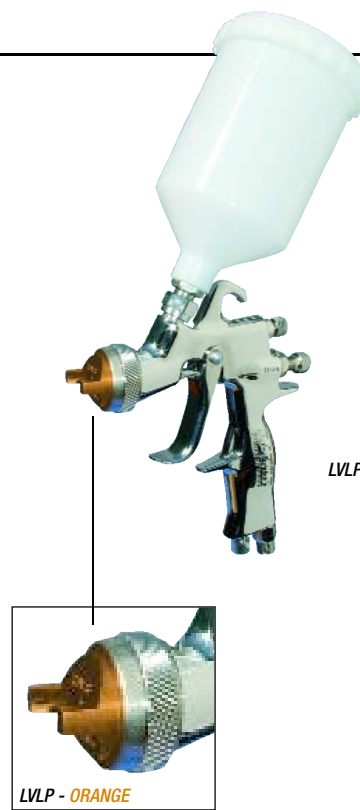

Ordering Information

Gun Part No.	Air Cap	Nozzle	Needle Tip & Assembly	Air Consumption	Air Inlet Size	Recommended Usage	Instruction Manual
288561 1.2 mm	253823	253802	288751 – tip 253769 – assy	249 lpm @ 1.1 bar (16 psi)	1/4" npsm(m)	Clear and base coats	312101
288562 1.3 mm	253823	253803	288752 – tip 253771 – assy	249 lpm @ 1.1 bar (16 psi)	1/4" npsm(m)	Clear and base coats	312101
288563 1.4 mm	253823	253804	253917 – tip 253772 – assy	249 lpm @ 1.1 bar (16 psi)	1/4" npsm(m)	Clear and base coats	312101
288564 1.5 mm	253823	253805	253917 – tip 253772 – assy	249 lpm @ 1.1 bar (16 psi)	1/4" npsm(m)	Clear and base coats	312101
288565 1.6 mm	253823	253806	288753 – tip 253773 – assy	249 lpm @ 1.1 bar (16 psi)	1/4" npsm(m)	Clear and base coats	312101

RAZOR

Compliant Spray Gun

Features and Benefits

- Provides that perfect blend of first rate atomization and extraordinary transfer efficiency that today's painters desire
- Lightweight, ergonomic gun body for painter comfort
- Offers wide spray patterns and remarkable material flow
- Optimized for exceptionally fine atomization

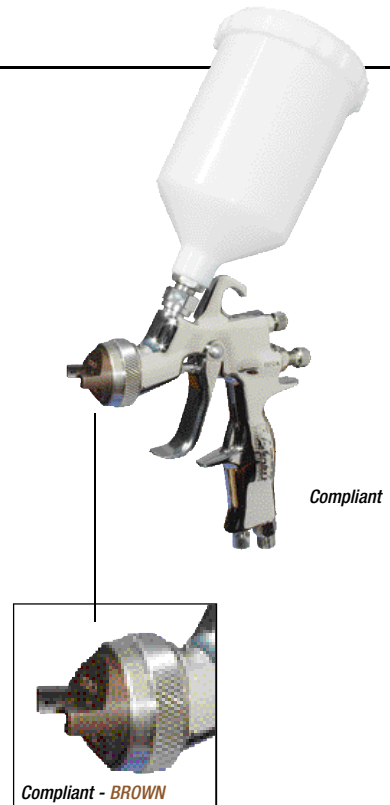

Ordering Information

Gun Part No.	Air Cap	Nozzle	Needle Tip & Assembly	Air Consumption	Air Inlet Size	Recommended Usage	Instruction Manual
288575 1.0 mm	253825	253816	288751 – tip 253769 – assy	317 lpm @ 2.4 bar (35 psi)	1/4" npsm(m)	Clear and base coats	312101
288576 1.2 mm	253825	253817	288751 – tip 253769 – assy	317 lpm @ 2.4 bar (35 psi)	1/4" npsm(m)	Clear and base coats	312101
288577 1.3 mm	253825	253818	288752 – tip 253771 – assy	317 lpm @ 2.4 bar (35 psi)	1/4" npsm(m)	Clear and base coats	312101
288578 1.4 mm	253825	253819	288752 – tip 253771 – assy	317 lpm @ 2.4 bar (35 psi)	1/4" npsm(m)	Clear and base coats	312101
288657 1.5 mm	253825	288653	253917 – tip 253772 – assy	317 lpm @ 2.4 bar (35 psi)	1/4" npsm(m)	Primer	312101
288579 1.6 mm	253825	253820	253917 – tip 253772 – assy	317 lpm @ 2.4 bar (35 psi)	1/4" npsm(m)	Primer	312101
288580 2.0 mm	253826	253821	234779 – tip 253774 – assy	317 lpm @ 2.4 bar (35 psi)	1/4" npsm(m)	Primer	312101
288581 2.5 mm	253826	253822	234780 – tip 253775 – assy	317 lpm @ 2.4 bar (35 psi)	1/4" npsm(m)	Primer	312101

RAZOR

Conventional Spray Gun

Features and Benefits

- Offers a wide variety of nozzle sizes
- Meets the needs of high pressure applications
- Provides wide spray patterns and remarkable material flow
- Optimized for exceptionally fine atomization



Conventional

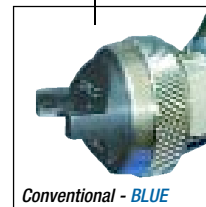

Ordering Information

Gun Part No.	Air Cap	Nozzle	Needle Tip & Assembly	Air Consumption	Air Inlet Size	Recommended Usage	Instruction Manual
288582 1.2 mm	288451	288295	253917 – tip 253772 – assy	376 lpm @ 3.0 bar (43 psi)	1/4" npsm(m)	Clear and base coats	312101
288583 1.3 mm	288451	288296	253917 – tip 253772 – assy	376 lpm @ 3.0 bar (43 psi)	1/4" npsm(m)	Clear and base coats	312101
288584 1.4 mm	288451	288297	288752 – tip 253771 – assy	376 lpm @ 3.0 bar (43 psi)	1/4" npsm(m)	Clear and base coats	312101
288585 1.6 mm	288451	288298	253917 – tip 253772 – assy	376 lpm @ 3.0 bar (43 psi)	1/4" npsm(m)	Clear and base coats	312101
288586 1.8 mm	288452	288299	253917 – tip 253772 – assy	424 lpm @ 3.0 bar (43 psi)	1/4" npsm(m)	Primer	312101
288587 2.5 mm	288453	288300	234780 – tip 253775 – assy	382 lpm @ 3.0 bar (43 psi)	1/4" npsm(m)	Primer	312101

RAZOR

Siphon Spray Guns

Features and Benefits

- Superior clear coat, base coat and primer capabilities
- Lightweight, ergonomic gun body for painter comfort
- Offers wide spray patterns and remarkable material flow
- Optimized for exceptionally fine atomization
- System includes Razor siphon feed spray gun and cup assembly (244130)



Siphon

Ordering Information

Gun Part No.	Air Cap	Nozzle	Needle Tip & Assembly	Air Consumption	Air Inlet Size	Recommended Usage	Instruction Manual
HVLP Siphon							
288588 2.2 mm	253827	253778	234779 – tip 253777 – assy	317 lpm @ 2.1 bar (30 psi)	1/4" npsm(m)	Clear and base coats	312106
Compliant Siphon							
288589 1.0 mm	288454	288301	288751 – tip 288640 – assy	294 lpm @ 2.4 bar (35 psi)	1/4" npsm(m)	Clear and base coats	312106
288590 1.2 mm	288454	288302	243778 – tip 288641 – assy	294 lpm @ 2.4 bar (35 psi)	1/4" npsm(m)	Clear and base coats	312106
288591 1.3 mm	288454	288303	243778 – tip 288641 – assy	294 lpm @ 2.4 bar (35 psi)	1/4" npsm(m)	Clear and base coats	312106
288592 1.4 mm	288454	288304	288752 – tip 288642 – assy	294 lpm @ 2.4 bar (35 psi)	1/4" npsm(m)	Clear and base coats	312106
288593 1.6 mm	288454	288305	288752 – tip 288642 – assy	294 lpm @ 2.4 bar (35 psi)	1/4" npsm(m)	Clear and base coats	312106
288594 1.8 mm	288454	288306	253917 – tip 288643 – assy	294 lpm @ 2.4 bar (35 psi)	1/4" npsm(m)	Primer	312106
Conventional Siphon							
288595 1.5 mm	288455	288307	288752 – tip 288642 – assy	345 lpm @ 3.0 bar (43 psi)	1/4" npsm(m)	Clear and base coats	312106
288596 1.8 mm	288455	288308	288752 – tip 288642 – assy	345 lpm @ 3.0 bar (43 psi)	1/4" npsm(m)	Clear and base coats	312106
288597 2.0 mm	288456	288309	234779 – tip 253777 – assy	382 lpm @ 3.0 bar (43 psi)	1/4" npsm(m)	Primer	312106
288598 2.5 mm	288457	288310	234779 – tip 253777 – assy	370 lpm @ 3.0 bar (43 psi)	1/4" npsm(m)	Primer	312106

LT SERIES

High quality finishing at an affordable price

LT SERIES

Gravity Feed Series

Features and Benefits

- Well-balanced and lightweight reduces painter fatigue
- Ships complete with durable, aluminum cups
- High-end features at an affordable price
- Worry-free use ensured by our commitment to quality

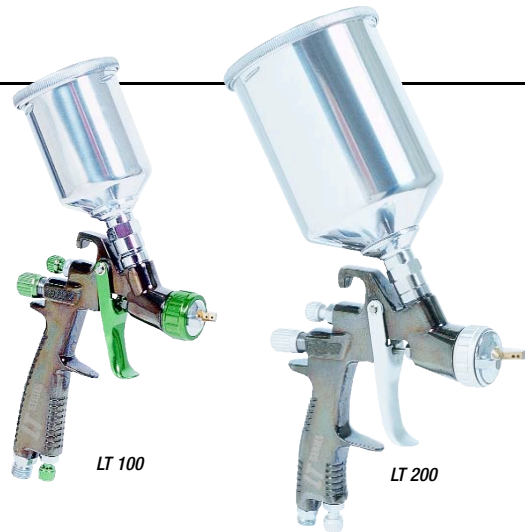

Ordering Information

Gun Part No.	Air Cap	Fluid Tip & Fluid Needle	Air Consumption	Air Inlet Size	Instruction Manual	Repair Kit
LT 100 – Mini-HVLP						
249346 1.0 mm	15G123	15G124 – tip 15G136 – needle	138 lpm @ 1.9 bar (29 psi)	1/4" npsm(m)	311104	249510
LT 200 – Conventional						
249347 1.4 mm	15G157	15G151 – tip 15G170 – needle	336 lpm @ 1.9 bar (29 psi)	1/4" npsm(m)	311104	249511
249348 1.8 mm	15G157	15G153 – tip 15G156 – needle	336 lpm @ 1.9 bar (29 psi)	1/4" npsm(m)	311104	249511
LT 300 – HVLP						
249349 1.3 mm	15G149	15G150 – tip 15G154 – needle	322 lpm @ 1.9 bar (29 psi)	1/4" npsm(m)	311104	249511
249350 1.4 mm	15G149	15G151 – tip 15G170 – needle	322 lpm @ 1.9 bar (29 psi)	1/4" npsm(m)	311104	249511
249351 1.5 mm	15G149	15G152 – tip 15G155 – needle	322 lpm @ 1.9 bar (29 psi)	1/4" npsm(m)	311104	249511
249352 1.8 mm	15G149	15G153 – tip 15G156 – needle	322 lpm @ 1.9 bar (29 psi)	1/4" npsm(m)	311104	249511

Gravity Feed Cups

Gravity Feed Cup Assemblies

for use on all Gravity Feed Spray Guns

RAZOR Plastic Gravity Cup

Part No. 288661

- ▶ 600 cc capacity
- ▶ Rapid thread size of 5/8-11 UNC 2A
- ▶ Lid assembly (part no. 15K136)

RAZOR Polished Aluminum Gravity Feed Cup

Part No. 253977

- ▶ 650 cc capacity (23 oz)
- ▶ Rapid thread size of 5/8-11 UNC 2A – for RAZOR guns excluding primer
- ▶ Lid assembly (part no. 22104)

LT SERIES Aluminum Gravity Feed Cup

LT 100

Part No. 15G148

- ▶ 150 cc capacity (5 oz)
- ▶ Gasket kit 253418 (contains 5 gaskets)
- ▶ Lid assembly (part no. 15F402)

LT SERIES Aluminum Gravity Feed Cup

LT 200/LT300

Part No. 15G177

- ▶ 600 cc capacity (20 oz)
- ▶ Gasket kit 253417 (contains 5 gaskets)
- ▶ Lid assembly (part no. 15F403)

PPS™ Adapters

Part No. 253975

- ▶ PPS Adapter for most RAZOR guns

3M's PPS™ Accessories

- 234941 150 ml (6 oz) 3M PPS Cup and Collar (box of 8)
For use with gravity and siphon feed guns.
- 234940 150 ml (6 oz) 3M PPS Lid and Liner (box of 50)
150 ml cup liner
- 234771 650 ml (25 oz) 3M PPS Cup and Collar (box of 8)
For use with gravity and siphon feed guns.
- 234772 650 ml (25 oz) 3M PPS Lid and Liner (box of 50)
650 ml cup liner
- 234937 850 ml (32 oz) 3M PPS Cup and Collar (box of 4)
For use with gravity and siphon feed guns.
- 234938 850 ml (32 oz) 3M PPS Lid and Liner (box of 25)
850 ml cup liner
- 234837 3M PPS Kit (one each: cup, collar, lid, liner, adapter)
Gravity Kit 650 ml (25 oz)
- 234773 3M PPS Kit (one each: cup, collar, lid, liner, adapter)
Siphon Kit 650 ml (25 oz)
- 15E470 3M PPS Lid Dispenser
- 15E469 3M PPS Liner Dispenser
- 15E467 3M PPS Gun Tray



Part No. 288661
600 cc capacity



Part No. 253977
650 cc capacity



Part No. 15E422
150 cc capacity



Part No. 15E449
600 cc capacity



Part No. 253975
PPS Adapter



Cup Assemblies / Air Adjusting Valves

Cup Assemblies

Siphon Cup Assembly

Part No. 244130

- ▶ Aluminium cup
- ▶ Features an indirect air vent to prevent dripping
- ▶ Attachment thread 3/8" npsm(f) swivel nut
- ▶ 1 liter (one quart) capacity



Low Pressure Cup Assembly

Part No. 239801

- ▶ Stainless steel cup
- ▶ Designed for use with pressure feed spray guns
- ▶ Clamp-type assembly
- ▶ Attachment thread 3/8" npsm(f); R 318-19 swivel nut
- ▶ 1 liter (one quart) capacity
- ▶ 0,8 bar (12 psi) maximum outlet pressure



Pressure Cup Regulator Set

Part No. 235375

- ▶ Includes pressure gauge
- ▶ Air inlet 1/4" npsm(m)
- ▶ Air outlet 1/4" npsm(f) swivel nut



Air Adjusting Valves

High-Volume Air Adjusting Valve

Part No. 288744

- ▶ High volume air adjusting valve designed especially for HVLP spray guns
- ▶ Includes pressure gauge that reads up to 11 bar (160 psi)
- ▶ Air inlet 1/4" npsm(m)
- ▶ Air outlet 1/4" npsm(f) swivel nut



High Output Valve

Part No. 234387

- ▶ Small, lightweight unit attaches to any HVLP spray gun for precise air pressure setting at the gun
- ▶ Easy to read 0-11 bar (0-160 psi) gauge
- ▶ Air inlet 1/4" npsm(m)
- ▶ Air outlet 1/4" npsm(f) swivel nut



Digi-tell™

Part No. 288652

- ▶ Pressure range up to 7 bar (100psi) supports a variety of air consumption needs
- ▶ Solvent resistant for gun washer use*
- ▶ PSI or bar setting capability
- ▶ Long 4 year battery life*
- ▶ Universal 1/4" nps fittings fit most spray guns
- ▶ Motion sensing display conserves battery life
- ▶ Accuracy range to $\pm 0,03$ bar ($\pm 0,5$ psi)



* Based on normal usage

Air Regulators

Reliable air regulators for low-pressure car refinishing applications

Regulators

Air Regulators

Part No.	Description	Air Inlet	Air Outlet	Handle	Repair Kit	Maximum Inlet Pressure bar (psi, MPa)	Maximum cfm at 3.4 bar (50 psi, .34 MPa)	Instruction Manual
234389	Air Regulator with gauge, self relieving	1/4" npt(m)	1/4" npt(f)	knob	289167	11 bar (160 psi)	623 lpm	309924
234434	Air Regulator with gauge, self relieving	1/4" npt(m)	1/4" npt(f)	knob	289167	11 bar (160 psi)	991 lpm	309924
234390	Mini Air Regulator with gauge	1/4" npt(f)	1/4" npt(f)	knob	289167	11 bar (160 psi)	623 lpm	309924

Air Regulators

Part No.	Description	Air Inlet	Air Outlet	Handle	Repair Kit	Maximum Inlet Pressure bar (psi, MPa)	Maximum cfm at 7 bar (100 psi, 0.7 MPa)	Instruction Manual
234391	Air Regulator with 2 regulated outlets 1 unregulated outlet	3/8" npt(f)	1/4" npt(f)	tee	289167	12 bar (175 psi)	1415 lpm	309924
234392	Air Regulator with 3 regulated outlets	3/8" npt(f)	1/4" npt(f)	tee	289167	12 bar (175 psi)	1415 lpm	309924
234393	Air Regulator 234391 with gauge and shutoff valve, 1 regulated outlet 1 unregulated outlet	3/8" npt(m)	1/4" npt(f)	tee	289167	11 bar (160 psi)	1415 lpm	309924
234394	Air Regulator 234392 with gauge and shutoff valve, 2 regulated outlets	3/8" npt(m)	1/4" npt(f)	tee	289167	11 bar (160 psi)	1415 lpm	309924



Part No. 234391



Part No. 234393



Part No. 234390

Air Filters / Air Control Units

In-line air filters and air filter/regulator systems for low-pressure applications

Air Filters

Ordering Information

Part No.	Filtration	Air Inlet	Air Outlet	Max. Operating Pressure	Capacity	Filter Element	Instruction Manual
234410	5 micron	1/2" npsm(f)	3/8" npsm(f) and 1/4" npsm(f) plugged	12 bar (175 psi)	Filter: 2125 lpm	289183	309923
234412	5 micron	1/4" npsm(f)	1/4" npsm(f) and 1/4" npsm(f) plugged	12 bar (175 psi)	Filter: 2125 lpm	289183	309923
234396	5 micron	1/2" npsm(f)	3/8" npsm(f)	12 bar (175 psi)	Filter: 3400 lpm	288783	309923



Part No. 234410

Air Control Units

Ordering Information

Part No.	Filtration	Air Inlet	Air Outlet	Max. Operating Pressure	Capacity	Filter Element	Instruction Manual
234398	5 micron	1/2" npsm(f)	1/4" npsm(f)	12 bar (175 psi)	Filter: 3400 lpm Regulator: 1415 lpm	288783	309923
234399	5 micron	1/2" npsm(f)	1/4" npsm(f)	12 bar (175 psi)	Filter: 3400 lpm Regulator: 1415 lpm	288783	309923
234400	5 micron	1/2" npsm(f)	1/4" npsm(f)	12 bar (175 psi)	Filter: 3400 lpm Regulator: 1415 lpm	288783	309923
234411	5 micron	1/2" npsm(f)	1/4" npsm(f)	12 bar (175 psi)	Filter: 2125 lpm Regulator: 1415 lpm	289183	309923



Part No. 234399



Part No. 234400

In-Line Filters

Components and systems to remove water, oil and contaminants from compressed air

In-Line Filters

Ordering Information

Part No.	Description	Filtration	Air Flow Capacity	Outlet Size	Max. Temperature	Max. Operating Pressure	Filter Element	Instruction Manual
234405	Air filter (234406) and coalescer (234407) assembly	5 micron	1982 lpm	1/2" npsm(f)	65°C (150°F)	12 bar (175 psi)	288809 289193	309919
234408	Air filter	5 micron	1982 lpm	3/4" npsm(f)	65°C (150°F)	12 bar (175 psi)	288807	309919
234409	Coalescer	5 micron	3256 lpm	3/4" npsm(f)	65°C (150°F)	12 bar (175 psi)	118559	309919



Part No. 234405



Part No. 234408



Part No. 234409

Air Drying Systems

Clean, dry air for all air-operated equipment

Dryaire™ Membrane System

Features and Benefits

Model 234418

- ▶ Maintains -40°C dew point while achieving 0% compressed air humidity
- ▶ Removes oil and sub-micron particles down to 0.01 micron
- ▶ Maintenance-free membrane dryer - no refrigerants or desiccants to replace - no regeneration required
- ▶ Lightweight, easy-to-install, simple to operate
- ▶ Filtering capacity 850 lpm @ up to 12 bar (175 psi)
- ▶ Stage one replacement filter (part no. 288809)
- ▶ Stage two replacement coalescer (part no. 289193)
- ▶ Instruction manual 309920

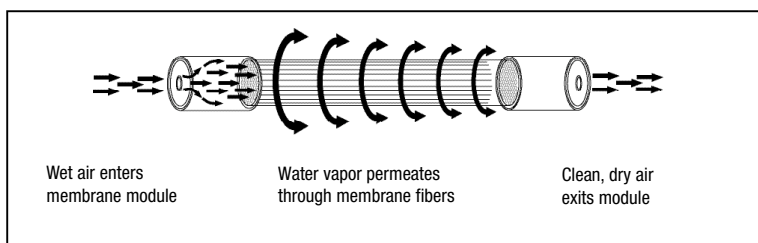

Dryaire™ Desiccant System

Features and Benefits

Model 234401

- ▶ Maintains -40°C dew point while achieving 0% compressed air humidity
- ▶ Removes oil particles down to 0.01 micron
- ▶ Contains desiccant beads which change colour when saturated
- ▶ Filtering capacity 850 lpm, up to 12 bar (175 psi)
- ▶ Self-relieving air regulator, mounting bracket, and shut-off valve included
- ▶ Replacement desiccant beads, four-1 gallon (part no. 288810)
- ▶ Instruction manual 309921

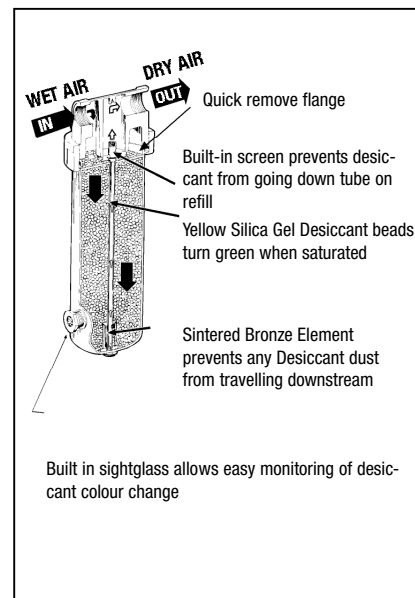

Pressure Systems

Sturdy, durable general purpose pressure tanks and Cups

Pressure Cups

2 liter (2-Quart) Pressure Cup

Part No. 288776

- ▶ For use with any pressure feed spray gun when more than one quart of material is desired
- ▶ Wide mouth for easy clean-up
- ▶ Cup pressure regulator (part no. 234434) allows for fluid pressure adjustments 0-3,5 bar (0-50 psi)
- ▶ Order with 6 ft hose kit (part no. 7130)
- ▶ Instruction manual 312111



Pressure Tanks

2.5 Gal Pressure Tanks

Single Regulation

Part No. 234414

- ▶ For use over 9,5 liter (2 gallon)
- ▶ PTFE lined for easy clean-up
- ▶ Tank pressure regulator (part no. 234393) allows fluid pressure adjustment 0-5,5 bar (0-80 psi)
- ▶ Order with part no. 7210 and 7220 hose assemblies
- ▶ Instruction manual 309924

Dual Regulation

Part No. 234415

- ▶ Same as part no. 234414 except includes an additional air regulator (part no. 234392) for the painter who prefers regulating his atomizing air at the tank

2.5 Gal Disposable Tank Liners

Part No. 289136 (not shown)

Pack of 5

- ▶ Durable design, rigid for repeat use
- ▶ Instruction manual 309924

5 Gal Pressure Tanks

Single Regulation

Part No. 234416

- ▶ Same as part no. 234414 except with 19 liter (5 gallon) capacity

Dual Regulation

Part No. 234417

- ▶ Same as part no. 234415 except with 19 liter (5 gallon) capacity



Accessories

Gravity Feed Filling Station

Part No. 9893

- Designed to hold up to 3 guns in place while filling
- Adjustable strainer holder

Gravity Feed Spray Holder

Part No. 9894

- Designed to hold up to 4 guns
- Mounts on wall or table

Hose Assemblies with Reusable Connectors

- Part No. 7110 6 ft, 5/16 in ID air hose with 1/4" npsm(f) connectors
- Part No. 7120 6 ft, 1/4 in ID fluid hose with 3/8" npsm(f) connectors
- Part No. 7130 6 ft, hose kit for 2-liter pressure cup includes one each Models 7110 and 7120
- Part No. 7210 25 ft, 3/8 in ID air hose with 1/4" npsm(f) connectors
- Part No. 7220 25 ft, 3/8 in ID fluid hose with 3/8" npsm(f) connectors
- Part No. 7230 35 ft, 3/8 in air hose assembly with high-volume quick couplers and connectors

High-Volume Hose Connectors

- Part No. 8310 High volume 1/4" female quick coupler
- Part No. 8320 High volume 1/4" male quick coupler
- Part No. 8330 Quick connect 1/4" female connectors
- Part No. 8340 Quick connect 1/4" male connectors

Spray Gun Lube

Part No. 111265

- Keep your spray guns operating smoothly
- Compatible with all paint materials
- Convenient and easy-to-use applicator

Spray Gun Brush Kit

Part No. 15C161

- Brush kit effectively cleans any spray gun model
- Includes one spray gun lube applicator



Part No. 9894



Part No. 9893



Part No. 8310



Part No. 8320



Part No. 8330



Part No. 8340



Part No. 7230

Additional Information

Metric to Decimal Conversion Chart

Conversion Chart

.15 mm = .0059 in	1.0 mm = .0394 in	1.9 mm = .0748 in
.20 mm = .0078 in	1.1 mm = .0433 in	2.0 mm = .0787 in
.25 mm = .0098 in	1.2 mm = .0472 in	2.1 mm = .0827 in
.35 mm = .0138 in	1.3 mm = .0512 in	2.2 mm = .0866 in
.50 mm = .0197 in	1.4 mm = .0551 in	2.3 mm = .0906 in
.60 mm = .0236 in	1.5 mm = .0591 in	2.4 mm = .0945 in
.70 mm = .0276 in	1.6 mm = .0630 in	2.5 mm = .0984 in
.80 mm = .0315 in	1.7 mm = .0669 in	3.0 mm = .1181 in
.90 mm = .0354 in	1.8 mm = .0709 in	5.0 mm = .1969 in





ABOUT GRACO

Founded in 1926, Graco is a world leader in fluid handling systems and components. Graco products move, measure, control, dispense and apply a wide range of fluids and viscous materials used in vehicle lubrication, commercial and industrial settings.

The company's success is based on its unwavering commitment to technical excellence, world-class manufacturing and unparalleled customer service. Working closely with qualified distributors, Graco offers systems, products and technology that set the quality standard in a wide range of fluid handling solutions. Graco provides equipment for spray finishing, protective coating, paint circulation, lubrication, and dispensing sealants and adhesives, along with power application equipment for the contractor industry. Graco's ongoing investment in fluid management and control will continue to provide innovative solutions to a diverse global market.

GRACO LOCATIONS

CONTACT

MAILING ADDRESS

P.O. Box 1441
Minneapolis, MN 55440-1441
Tel: 612.623.6000
Fax: 612.623.6777

AMERICAS

MINNESOTA

Worldwide Headquarters
Graco Inc.
88-11th Avenue N.E.
Minneapolis, MN 55413

EUROPE

BELGIUM

European Headquarters
Graco N.V.
Industrieterrein-Oude Bunders
Slakweidestraat 31
3630 Maasmechelen,
Belgium
Tel: 32.89.770.700
Fax: 32.89.770.777

ASIA PACIFIC

JAPAN

Graco K.K.
1-27-12 Hayabuchi
Tsuzuki-ku
Yokohama City, Japan 2240025
Tel: 81.45.593.7300
Fax: 81.45.593.7301

ASIA PACIFIC

CHINA

Graco Hong Kong Ltd.
Representative Office
Room 118 1st Floor
No.2 Xin Yuan Building
No.509 Cao Bao Road
Shanghai, P.R. China 200233
Tel: 86.21.649.50088
Fax: 86.21.649.50077

ASIA PACIFIC

KOREA

Graco Korea Inc.
Choheung Bank Building
4th Floor #1599
Gwanyang-Dong, Dongan-Ku,
Anyang-Si, Gyunggi-Do,
Korea 431-060
Tel: 82(Korea).31.476.9400
Fax: 82(Korea).31.476.9801

All written and visual data contained in this document are based on the latest product information available at the time of publication.
Graco reserves the right to make changes at any time without notice.

Graco is certified ISO 9001.

Europe

+32 89 770 700
FAX +32 89 770 777
WWW.GRACO.BE